

# CANNON MACHINERY CASER SYSTEMS

## WhisperPak CC1500S Servo Caser



Top Left: **Valve Bank**

Top Middle: **HMI**

Top Right: **Infeed Clamps**

Bottom Left: **Servo Pusher**

<b>CONSTRUCTION</b>	Stainless steel frame, guards, conveyors, and control panel
<b>SAFETY</b>	<p>Fully enclosed with sliding full width doors for easy access to case, product, tables and heads            Dual channel door switches – Automatic E-Stop upon opening            Fixed infeed and discharge conveyor tunnel guards            Automatic energy isolation upon E-Stop (pneumatic and electric)</p> <ul style="list-style-type: none"> <li>• Dual channel safety relay opens control power circuits</li> <li>• Dual channel safe off servo drives</li> <li>• Fail safe brake on lowering unit actuator</li> </ul> <p>Dual sided control panel with isolated high and low voltage sections            All control wiring 24V DC            Soft shift master pneumatic valve for controlled restarts</p>
<b>OPERATION</b>	<p>Servo driven linear actuators provide precise high speed control for pushers and lowering unit            EMT- Energy Management Technology, minimizes shock to product and mechanical assemblies</p> <ul style="list-style-type: none"> <li>• Managed acceleration and deceleration on pusher and lowering unit allowing for higher speeds without impact</li> <li>• Composite materials used to reduce moving mass while retaining strength</li> <li>• Dynamic conveyor speed control for maximum product infeed speed with minimum product end stop impact</li> <li>• Soft shift master pneumatic valve for controlled restarts</li> </ul>
<b>CONTROLLER</b>	Allen Bradley CompactLogix with integrated Kinetix 5500 servo drives
<b>HMI</b>	<p>Allen Bradley PanelView – 6.5” or optional 10”            Displays operational status of machine functions, including alarms            Password protected access to machine operating parameters</p>
<b>ELECTRICAL</b>	480V, 60Hz, 3Ph; 24 Volt DC Controls, NEMA 4X electrical enclosures, IP 69K sensors
<b>CONVEYOR</b>	<p>Infeed product conveyor with high efficiency helical bevel gearmotors            Includes 6ft long non-powered case conveyor section</p>
<b>WARRANTY</b>	ONE-YEAR PARTS AND WORKMANSHIP

**cannonmachinery®**

**cannon**  
EQUIPMENT

324 West Washington St., Cannon Falls, MN 55009  
 Toll Free: 800-825-8501 • Direct: 507-263-6400  
 Email: [Info@CannonEquipment.com](mailto:Info@CannonEquipment.com)

# WhisperPak CC1500S

## Servo Caser

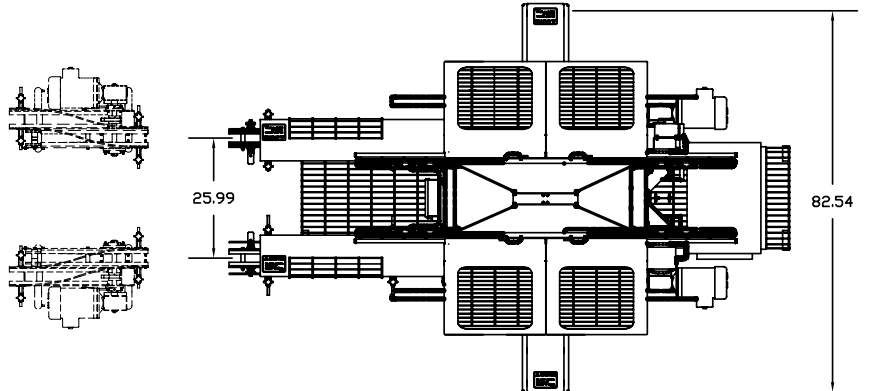

Option dynamic product infeed deceleration

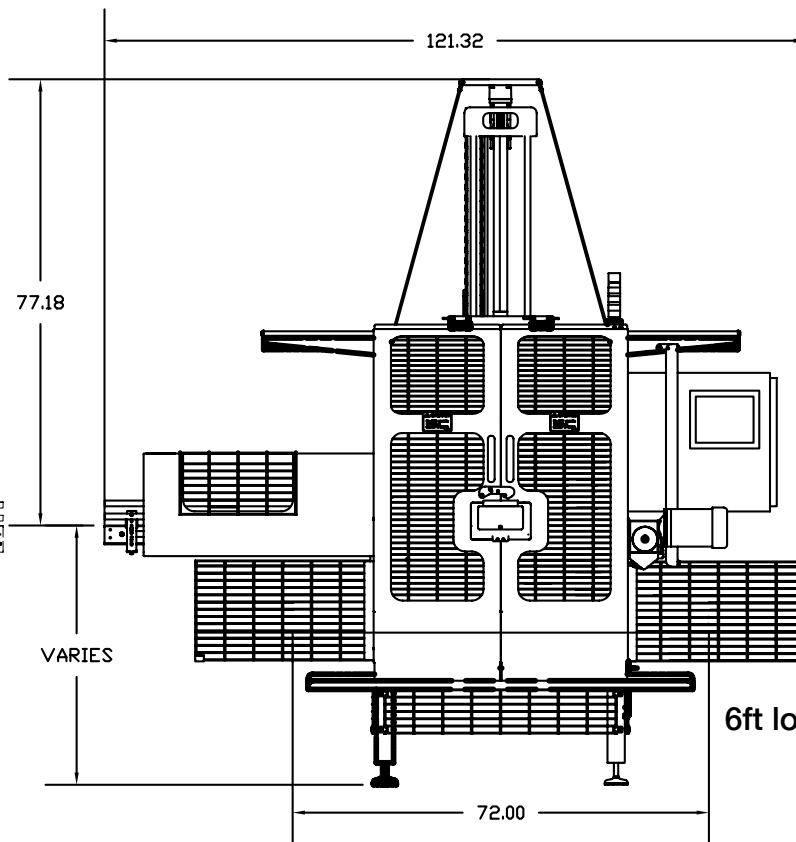
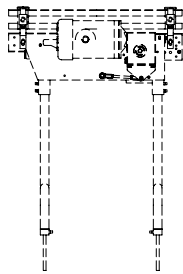

optional 10" panelview shown

6ft long case conveyor section

MODEL	LOAD METHOD	LOAD STATION	INFEEDS	PRODUCT PACKAGES	CASE TYPES	CONTROLLERS
CC-1500S	Gripper Head(s)	Single or Dual	Single or Dual	Gable Top Paper Cartons, Plastic Square Bottles	13x13 or 13x19 Plastic Cases RSC or Bliss Top-Load Boxes	Allen Bradley



324 West Washington St., Cannon Falls, MN 55009  
 Toll Free: 800-825-8501 • Direct: 507-263-6400  
 Email: Info@CannonEquipment.com