

SCALE HANGER SHORTY

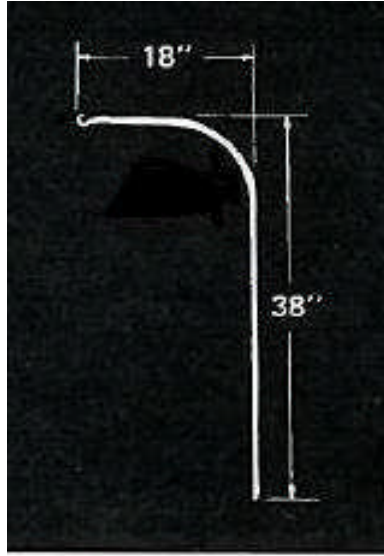

How Used

 Distribution

 Stocking

 Work-In-Process

 Display

Where Used



Retail

Description

This scale hanger is designed to hold dial scales in the produce sections of supermarkets, grocery stores, and retail locations. Mounting brackets are included for easy installation as well as heavy duty hooks to hold dial scales. The entire unit is constructed of 1-1/4" diameter steel tubing and has a chrome plated finish.

Specifications

Depth	18"	Casters	NA
Width	NA	Caster Size	NA
Height	38"	Caster Type	NA
Shelving	NA	Finish	Chrome Plated
Number of Sides	NA	Load Capacity	
Construction		Options	NA
Weight	6 lbs	Lead Time	6 – 8 Weeks
FOB Point	Cannon Falls, MN	Truckload Quantity	1500 per 53' trailer
			<small>(quantity is subject change due to customer shipping requirements)</small>